

G Series Technical Guide – 10615 Impeller

Identification



G5, G7, G7B & G50



G45-1



G45-2 & G46



M70 & M71



L10B



K90

Assembly / Disassembly Instructions

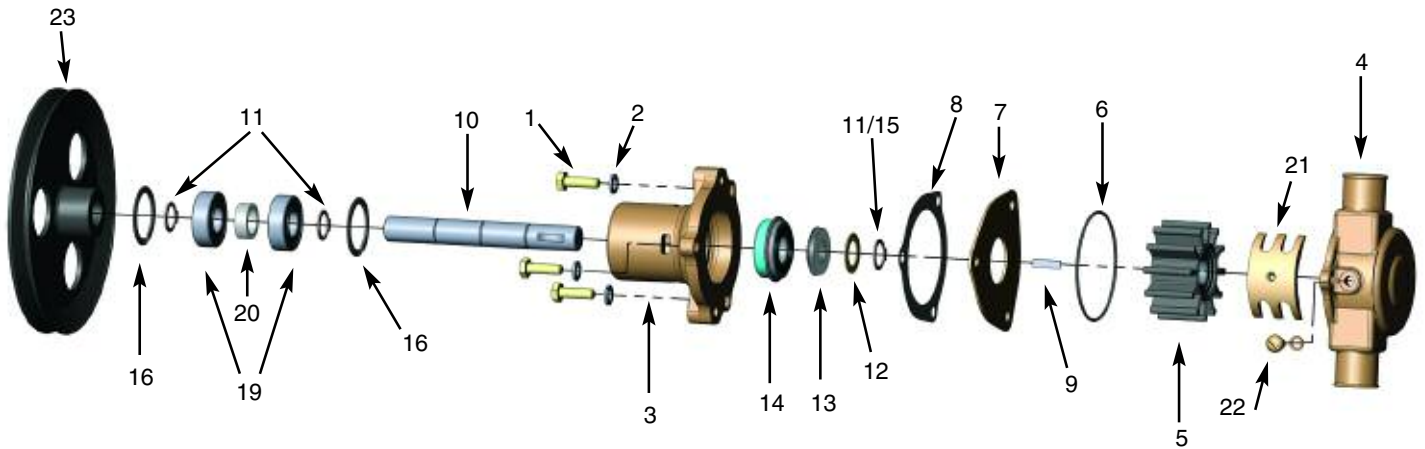

The following assembly/disassembly procedures apply to all G Series pumps. Deviations from pump to pump are primarily a result of different methods of drive and mounting.

Disassembly:

- A. Remove the screws (1) and lockwashers (2) that hold the body (3) and housing (4) together.
- B. The housing assembly including the impeller (5) can be removed from the body assembly, along with the o-ring (6), spacer plate (7) and gasket (8).
- C. Remove the woodruff key (9) from the shaft (10). If the shaft is to be used again, and if it is put in a vise, always use lead over the jaws of the vise so that the shaft is not damaged.
- D. Remove the retaining ring (11 or 15) from the shaft (impeller end). The shoulder washer (12) and seat assembly (13) can now be removed.
- E. From the drive end of the pump (pulley end, hub end, shaft end), remove retaining ring, remove pin (17), remove woodruff key (18) and loosen setscrew if used. NOTE: If the pulley (23) or hub (24) is pressed on the shaft, it will be necessary to locate a support directly between the pump body and pulley or hub as close to the shaft as possible. Press the shaft out of the pulley or hub. Make sure the body is free and not supported.
- F. For the M71, remove the two bolts that hold the aluminum adapter onto the bearing body. Pull the adapter off of the bearing body and press the up seal out of the adapter.
- G. Remove the large internal retaining ring (16) from the body at the end of the bearing.
- H. Support the body, and press the shaft, bearings (19), spacer (20) and retaining rings (11) out through the bearing or pulley end of the body.
- I. The seal assembly (14) is pressed into the body. It can be removed by pushing a tool through the bearing end and up against the metal or back side of the seal. NOTE: On some pumps, there is a spacer located between the pulley (hub) and bearing on the shaft. On other pumps, the bearings are positioned on the shaft with a retaining ring on each end. Support the bearings on the inner race, and push the shaft out of the bearings.

Assembly:

- A. When assembling the cam (21), put Permatex #1 on the backside of the cam and the screw (22) that retains the cam. Wipe off any Permatex that gets into the impeller cavity.
- B. Assemble a retaining ring (11) on the shaft into the second groove from the impeller end. Push the ball bearing (19) over the shaft (10). Press on the inner race of the bearing. Push the bearing up against the retaining ring. (Push the bearing on from the pulley or drive end, except for M71 pumps). Assemble a spacer and then the second ball bearing. Assemble the second retaining ring over the shaft and up against the ball bearing, if required.
- C. There is a large internal retaining ring (16) located in the body that provides a shoulder for the bearings (approximately 1.38" from the bearing end of the body). If it has been removed, it must be inserted at this time.
- D. Press the mechanical seal (14) into the body from the impeller end. Make sure that seal is pressed in square. A tool should be used to assure proper assembly.
- E. Push the bearing and shaft assembly into the body using care not to cock the bearing. A tool is recommended that will give you uniform pressure on the bearing outer race. Lock the bearing in place with the large internal retaining ring.
- F. Assemble the seat assembly (13), shoulder washer (12) and retaining ring (11 or 15) over the shaft from the impeller end. Locate the white ceramic surface against the seal – Do not damage the white ceramic surface of the seat, or the seal and seat assembly might leak. Lubricate the rubber part of the seat and use a tool for ease of assembly.
- G. For the M71, press a new lip seal into the aluminum adapter (with the metal backing ring away from the engine). Replace the adapter onto the bearing body, and tighten the two bolts.

Assembly / Disassembly Instructions (continued)

- H. While supporting the shaft, press the pulley/gear (23) or hub (24) onto the shaft. Secure pulley/hub with pin (17) or key (18) and retaining ring or setscrew as needed.
- I. Press the woodruff key (9) into the shaft. Make sure the stainless steel key is used at this location.
- J. Assemble the impeller (5) into the housing (4).
- K. Assemble the gasket (8) and spacer plate (7) on the body (3), and line up the screw holes. Replace the lockwashers (2), and tighten the screws (1).
- L. Make sure the o-ring (6) is properly located in the groove in the housing. A small dab of grease will help hold it in position until the housing to body screws are tightened.

Sherwood #		G5	G7	G7B	G45-1	G46	G50	G55-2	K90	L10B	M71	
Engine Manufacturer		Chrys.	Chrys.	Chrys.	Chris Craft	OMC	Chrys.		Isuzu			
Engine Model		318, 340	318, 360	318, 360	454	V8 Chevy	318, 340		4.6 Cyl Diesel			
ITEM	QTY	3675763	4142878	4142878	16.80-18347	985096	3619212		X-26-230-1023			
1	Screw	3	12857	12857	12857	12857	12857	12857	12857	12857	12857	
2	Lockwasher	3	12710	12710	12710	12710	12710	12710	12710	12710	12710	
3	Body	1	12227	12227	19789	12328	12328	12227	12328	12227	19948	14160
4	Housing	1	12228	12952	12952	12228	12952	12228	12907	12228	13899	12228
5	Impeller	1	10615	10615	10615	10615	10615	10615	10615	10615	10615	10615
6	O-ring	1	12231	12231	12231	12231	12231	12231	12231	12231	12231	12231
7	End Plate	1	12856	12856	12856	12856	12856	12856	12856	12856	12856	12856
8	Gasket	1	12855	12855	12855	12855	12855	12855	12855	12855	12855	12855
9	Key	1	4432	4432	4432	4432	4432	4432	4432	4432	4432	4432
10	Shaft	1	12233	13363	13363	12612	13363	12233	12596	12596	13363	14159
11	Retaining Ring (Ext)	2/3	4258	4258	4258	4258	4258	4258	4258	4258	4258	4258
12	Washer	1	4264	4264	4264	4264	4264	4264	4264	4264	4264	4264
15	Retaining Ring (Ext)	1	12305					12305				
16	Retaining Ring (Int)	2	4259	4259	4259	4259	4259	4259	4259	4259	4259	4259
17	Pin	1	11541			12791		11541	9420			
18	Key	1	12622					12622				
19	Ball Bearing	2	23448	23448	23448	23448	23448	23448	23448	23448	23448	23448
20	Spacer	1	5133	5133	5133	5133	5133	5133	5133	5133	5133	5133
21	Cam	1	10944	10929	10929	10944	10929	10944	10944	10944	10929	10944
22	Cam Screw	1	10515	10515	10515	10515	10515	10515	10515	10515	10515	10515
23	Drive Pulley or Gear	1	12326	15055	15055		15048	12323		14992		14184
24	Hub	1				12615		12926		13795		
13/14	Water Seal/Seat Assy	1	12859	12859	12859	12859	12859	12859	12859	12859	12859	12859
	Oil Seal	1										10514
	Minor Repair Kit		23976	23976	23976	23976	23976	23976	23976	23976	23976	23976
	Major Repair Kit		23977	23977	23977	23977	23977	23977	23977	23977	23977	23977

Inspection

The #1 reason for premature engine wear is overheating. To maintain engine performance, insist upon genuine Sherwood impellers and service kits.

Recommended inspection to be performed at any service interval:

- Impeller Inspect for cracks or tears. Also, inspect for excessive abrasion of vane ends. Replace annually, or if any of the conditions exist, as in the picture below.*
- Wear Plate Inspect for wear, flatness, and pin for fatigue. Replace at minor and major pump rebuild or if wear is evident to maintain pump flow and suction performance
- Cam Replace at major pump rebuild or if pitting/wear is evident.
- Cover Replace at major pump rebuild or if wear exists to maintain pump flow and suction performance.
- Mechanical Seal Replace at minor and major pump rebuild or if leaking.
- Lip Seal Replace at minor and major pump rebuild or if leaking.
- Shaft Inspect for wear in area of lip seal and rubber impeller. Grooving of lip seal area or heavy fretting of the impeller end shaft will require shaft replacement.
- Bearing Inspect for loss of grease, corrosion or rough rotation. Replace at major pump rebuild or if in doubt.

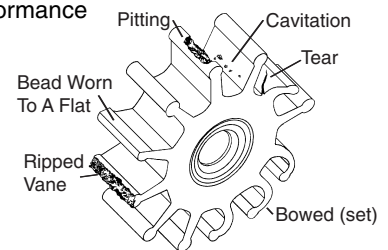

* See maintenance schedule on back page

Preventative Maintenance

Maintenance Schedule	Pleasure Boating (Low Hours)		Commercial/Fishing Use (High Hours)	
	Light Duty	Severe Duty (High RPM, Silt or Sand)	Heavy Duty	Severe Duty (High RPM, Silt or Sand)
Impeller Kit	Every year	6 months	6 months	3 months
Minor Kit	2 years	Every year	Every year	6 months
Major Kit	4 years	2 years	2 years	Every year

	Impeller Kit 10615K	Minor Kit 23976	Major Kit 23977
	1-10615 Impeller 1-12231 O-Ring 1-12855 Gasket	1-10615 Impeller 1-12231 O-Ring 1-12855 Gasket 1-12859 Seal 1-04258 Snap Ring 1-04432 Key 1-04264 Washer 2-04259 Snap Rings	1-10615 Impeller 1-12231 O-Ring 1-12855 Gasket 1-12859 Seal 3-04258 Snap Ring 1-04432 Key 1-04264 Washer 2-04259 Snap Rings 2-23448 Bearings 1-12856 End Plate 1-10929 Cam 1-10515 Cam Screw
G5	X	X	X
G7	X	X	X
G7B	X	X	X
G45-1	X	X	X
G46	X	X	X
G50	X	X	X
G55-2	X	X	X
K90	X	X	X
L10B	X	X	X
M71*	X	X	X

** Note: When using the Minor Kit 23976 or Major Kit 23977 for the M71, also replace the 10514 Lip Seal, which is not included in these kits.*

